

Crystal Resonator (晶体谐振器) - KX49M

Applications 应用

- Frequency sources, time references, video systems, communication systems, measuring instruments, computers, embedded systems, functional module 频率源, 时间基准, 视频系统, 通信系统, 测量仪器, 计算机, 嵌入系统, 功能模块等



General Specifications 规格参考

PARAMETER	性能参数	KX49M
Nominal Frequency	标准频率	3.5MHz ~ 80.0MHz
Oscillation Mode	振荡方式	基频/泛音
Equivalent Series Resistance	谐振电阻	8~100Ω
Frequency Tolerance (25°C±3°C)	调整频差	±5ppm~±30ppm
Load Capacitance	负载电容	Series or Parallel (8~32pF)
Storage Temperature Range	储存温度范围	-55~+125°C
Drive Level	激励电平	100μW typical, 500μW max
Shunt Capacitance	静电容	7pF max
Insulation Resistance	绝缘电阻	500MΩ min
Aging Per Year	老化率	±3ppm~±5ppm/year

Frequency Stability 温度频差 VS Operating Temperature Range 温度范围						
Temp. Code	Temp. \ppm	±10	±20	±30	±50	±100
B	-20~70°C	○	○	○	○	○
C	-40~85°C		○	○	○	○
F	-55~105°C				○	○
H	-55~125°C					○

Outline Dimensions (Unit: mm) 外形尺寸

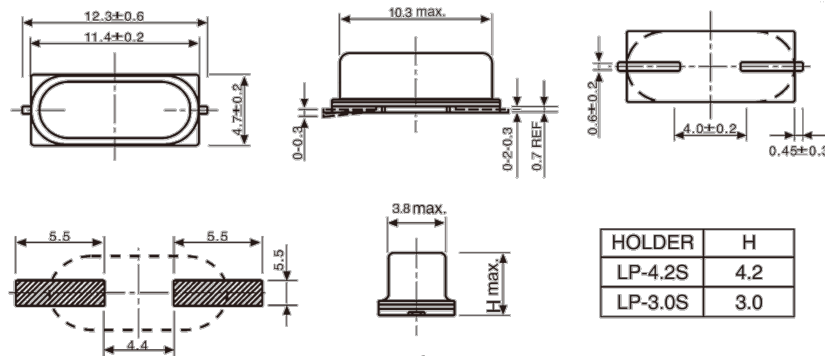

Part Number Guide 产品编号

KX49M - **24.576** - **F** - **20** - **C** - **30** - **30** - **NS**

型号	标称频率	振荡方式	负载	工作温度	调整频差	温度频差	特殊要求
'KX': 产品系列 '49M': 封装尺寸 MHz		F-基频 T-泛音		B: -20~+70°C C: -40~+85°C F: -55~+105°C H: -55~+125°C	05 = ±5ppm 10 = ±10ppm 15 = ±15ppm 20 = ±20ppm 30 = ±30ppm	10 = ±10ppm 20 = ±20ppm 30 = ±30ppm 50 = ±50ppm 100 = ±100ppm	'NS': 特殊要求

Reflow Solder 回流焊

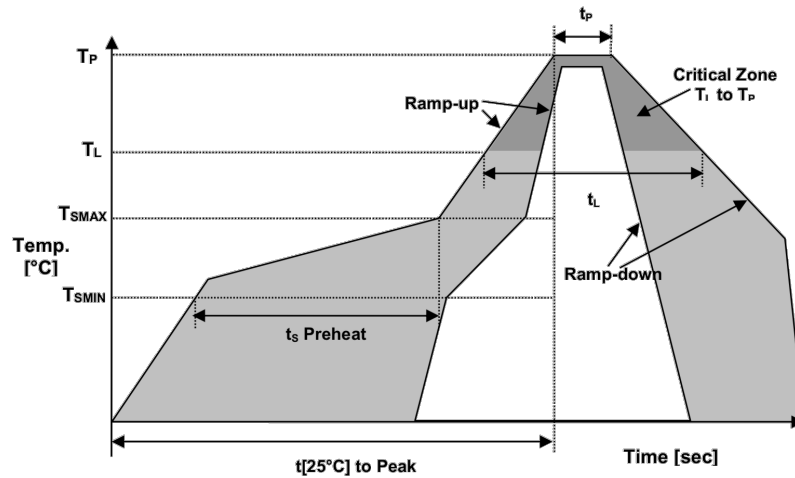

Temperature Min Preheat	最低预热温度	T _{Smin}	125°C
Temperature Max preheat	最高预热温度	T _{Smax}	150°C
Time (T _{Smin} to T _{Smax})	时间差	t _s	30~60 sec
Temperature	温度	T _L	217°C
Peak Temperature	最高温	T _P	260 °C
Ramp-up Rate	升温速度	R _{up}	3°C/sec max
Ramp-down Rate	降温速度	R _{down}	6°C/sec max
Time within 5°C of Peak Temperature	最高温度停留时间	t _p	10 sec
Time t[25°C] to peak temperature	25度到最高温度时间	t[25°C] to peak	120 sec
Time	时间	t _L	60~150 sec