

Clock Oscillator (时钟振荡器) - KJ706D

Feature 特征

Low phase jitter 0.6ps 低相位抖动;

Low current consumption 24mA for 622.080MHz @ 3.3V 低电流消耗



RoHS
Compliant
KOAN

Applications 应用

Mobile communications, radar navigation, digital products, HD monitoring, precision instruments 移动通信, 雷达导航, 数码产品, 高清监控, 精密仪器等

General Specifications 规格参考

PARAMETER	性能参数	数值
Frequency Range	频率范围	150MHz ~ 1.50GHz
Supply Voltage	供给电压	+2.5V/3.3V (±10%)
Output Logic	输出波形	LVDS
Frequency Tolerance	调整频差	±30ppm max
Frequency Stability	温度频差	见下表
Operating Temperature Range	温度范围	见下表
Current Consumption	工作电流	28mA max
Output Load	输出负载	100Ω between output and comp. output
Start-up Time	起振时间	8ms max
Duty Cycle	占空比	45~55%
Rise & Fall Time	上升下降时间	0.4ns max
Output Logic High "1"	输出电平 高	1.4V typ. 1.6V max
Output Logic Low "0"	输出电平 低	1.1V typ. 0.9V min
RMS Jitter	抖动	0.6ps typ. (12KHz~20MHz)
Storage Temperature Range	储存温度范围	-55°C ~ +125°C
Aging Per Year	年老化率	±3ppm ~ ±5ppm/year

Frequency Stability 温度频差 VS Operating Temperature Range 温度范围

Temp. Code	Temp. \ppm	±10	±20	±30	±50	±100
B	-20~70°C	○	○	○	○	○
C	-40~85°C		○	○	○	○
D	-55~85°C			○	○	○
E	-55~105°C				○	○
F	-55~125°C					○

NOTE: Please consult for other specifications 若有其它规格需求请告知

Outline Dimensions (Unit: mm) 外形尺寸

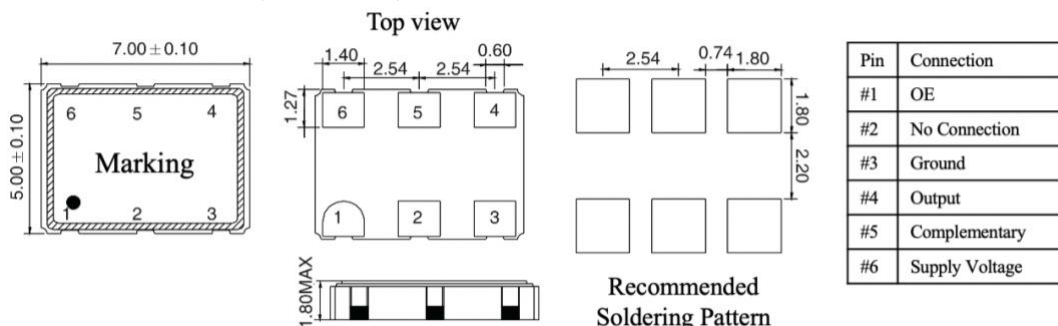

总部地址: 北京市海淀区知春路豪景大厦 B 座 802 室

公司官网: www.koan-xtal.com 联系电话: 010-62101903 传真: 010-62101561

Test Circuit and Output Waveforms 测试电路图及输出波形

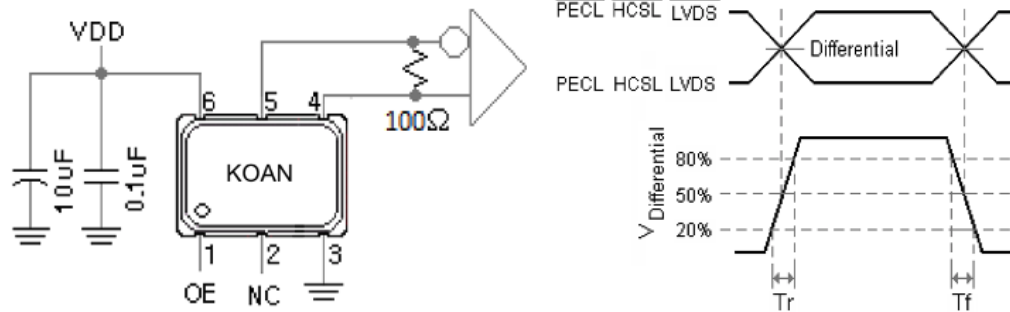

Part Number Guide 产品编号

KJ706D	-	622.080	-	33	-	C	-	30	-	
封装	-	标称频率	-	工作电压	-	工作温度	-	温度频差	-	特殊要求
'KJ':产品系列 K=KOAN J=低抖动 '706':封装尺寸 SMD 7.0x5.0mm 6 pad 'D':输出波形 LVDS				25=2.5V 33=3.3V	B: -20~+70°C C: -40~+85°C D: -55~+85°C E: -55~+105°C F: -55~+125°C	10 = ±10ppm 20 = ±20ppm 30 = ±30ppm 50 = ±50ppm 100 = ±100ppm	NS=特殊要求			

Reflow Profile 回流焊

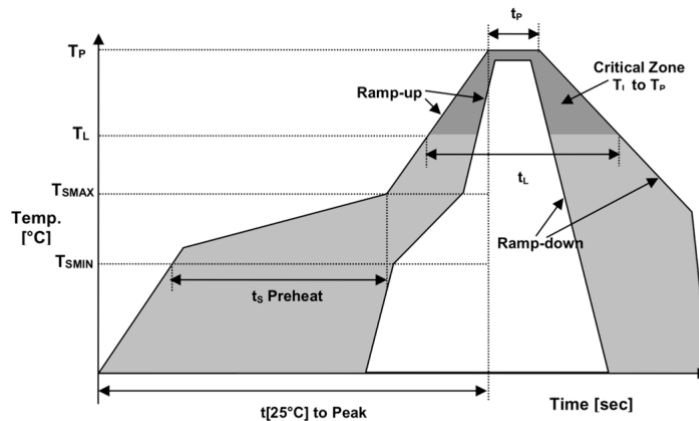

Temperature Min Preheat	最低预热温度	T_{smin}	150°C
Temperature Max preheat	最高预热温度	T_{smax}	200°C
Time (T_{smin} to T_{smax})	时间差	T_s	60~120 sec
Temperature	温度	T_L	217°C
Peak Temperature	最高温	T_p	260 °C
Ramp-up Rate	升温速度	R_{up}	3°C/sec max
Ramp-down Rate	降温速度	R_{down}	6°C/sec max
Time within 5°C of Peak Temperature	最高温度停留时间	t_p	30 sec
Time $t[25°C]$ to peak temperature	25度到最高温度时间	$t[25°C]$ to peak	480 sec
Time	时间	t_L	60~150 sec

Revision 版本

版本 Rev.	修改页 Revise Page	修改内容 Revise Contents	日期 Date	修改人 Reviser
0	N/A	Initial issue	2020.09.27	JH