

Clock Oscillator (时钟振荡器) - KD706D

Feature 特征

Low phase jitter 0.6pS 低相位抖动;

Low current consumption 24mA for 622.080MHz @ 3.3V 低电流消耗



Applications 应用

Mobile communications, radar navigation, digital products, HD monitoring, precision instruments 移动通信, 雷达导航, 数码产品, 高清监控, 精密仪器等

General Specifications 规格参考

PARAMETER	性能参数	KD706D	
Frequency Range	频率范围	10MHz~200MHz	10MHz ~ 1.5GHz
Supply Voltage	供给电压	+1.8V/2.5V/3.3V (±10%)	+2.5V/3.3V (±10%)
Output Logic	输出波形	LVDS	
Frequency Tolerance	调整频差	±30ppm max	
Frequency Stability	温度频差	见下表	
Operating Temperature Range	温度范围	见下表	
Current Consumption	工作电流	16mA typ.; 27mA max	38mA max
Output Load	输出负载	100Ω between output and comp. output	
Start-up Time	起振时间	5.0ms typ.; 10.0ms max	
Duty Cycle	占空比	45~55%	
Rise & Fall Time	上升下降时间	0.2ns typ.; 0.4ns max	
Output Enable/Disable Time	启动/禁用时间	Enable: 10ms max Disable: 0.2μs max	Enable: 200ns max Disable: 50ns max
Output Logic High "1"	输出电平 高	1.4V typ. 1.6V max	
Output Logic Low "0"	输出电平 低	1.1V typ. 0.9V min	
RMS Jitter(12KHz~20MHz)	抖动	0.2ps typ; 0.5ps max	1.0ps typ.
Storage Temperature Range	储存温度范围	-55°C ~ +125°C	
Aging Per Year	老化率	±3ppm ~ ±5ppm/year	

Frequency Stability 温度频差 VS Operating Temperature Range 温度范围						
Temp. Code	Temp.\ppm	±10	±20	±30	±50	±100
B	-20~70°C	○	○	○	○	○
C	-40~85°C		○	○	○	○
D	-55~85°C			○	○	○
E	-55~105°C				○	○
F	-55~125°C				○	○

NOTE: Please consult for other specifications 若有其它规格需求请告知

Outline Dimensions (Unit: mm) 外形尺寸

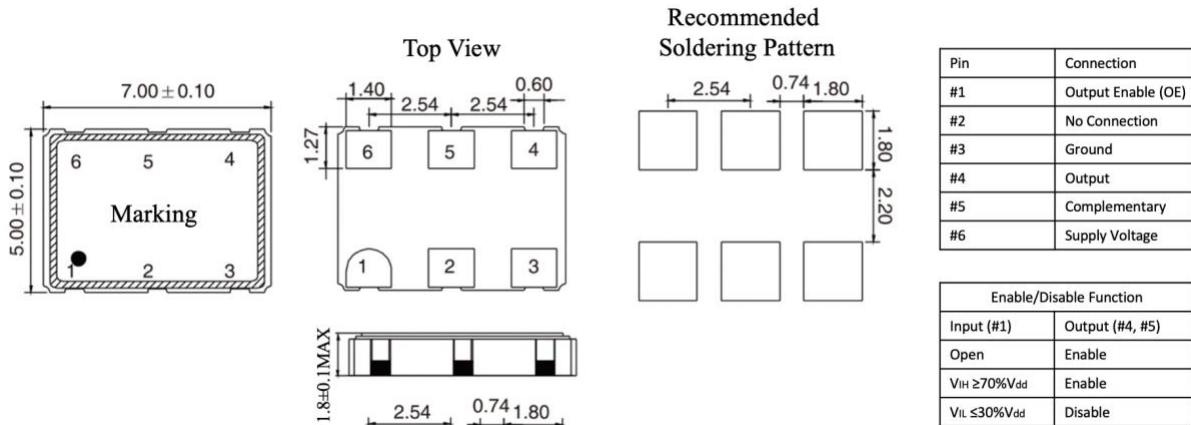

Test Circuit and Output Waveforms 测试电路图及输出波形

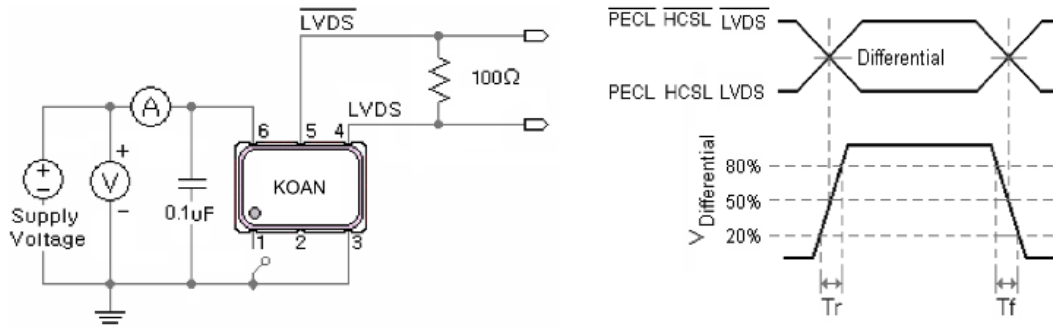

Part Number Guide 产品编号

KD706D	-	20.000	-	33	-	C	-	30	-	
封装	-	标称频率	-	工作电压	-	工作温度	-	温度频差	-	特殊要求
'KD':产品系列 K=KOAN D=差分 '706':封装尺寸 SMD 7.0x5.0mm 6 pad 'D':输出波形 LVDS				18=1.8V 25=2.5V 33=3.3V		B: -20~+70°C C: -40~+85°C D: -55~+85°C E: -55~+105°C F: -55~+125°C		10 = ±10ppm 20 = ±20ppm 30 = ±30ppm 50 = ±50ppm 100 = ±100ppm		NS=特殊要求

■ Reflow Profile 回流焊

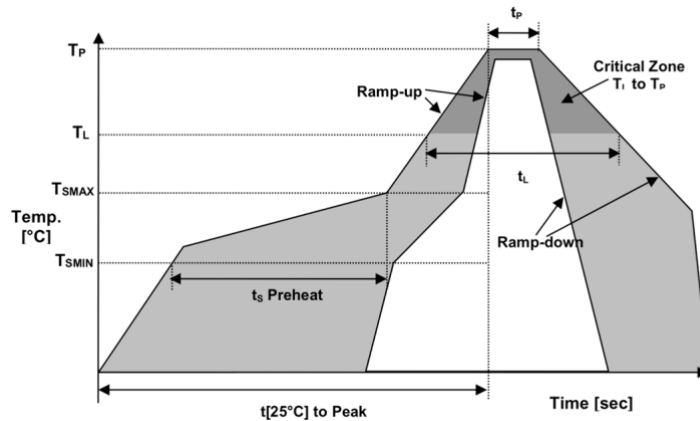

Temperature Min Preheat	最低预热温度	T_{smin}	150°C
Temperature Max preheat	最高预热温度	T_{smax}	200°C
Time (T_{smin} to T_{smax})	时间差	T_s	60~120 sec
Temperature	温度	T_L	217°C
Peak Temperature	最高温	T_p	260 °C
Ramp-up Rate	升温速度	R_{up}	3°C/sec max
Ramp-down Rate	降温速度	R_{down}	6°C/sec max
Time within 5°C of Peak Temperature	最高温度停留时间	t_p	30 sec
Time t[25°C] to peak temperature	25度到最高温度时间	t[25°C] to peak	480 sec
Time	时间	t_L	60~150 sec

■ Revision 版本

版本 Rev.	修改页 Revise Page	修改内容 Revise Contents	日期 Date	修改人 Reviser
1.0	2	Pin Description	2022.6.20	JZ