

时钟振荡器 Clock Oscillator: KD256C KD326C KD506C KD706C

Feature 特征

- Miniature 2.5x2.0mm package for space-constrained designs 小型化适合空间受限的设计
- HCSL differential output, ideals for high-speed serial interfaces HCSL 差分输出适用于高速串行接口应用
- Ultra-low phase jitter 0.2ps RMS typical, ensuring excellent timing stability 相位抖动极低, 时钟稳定性优秀
- Wide frequency range up to 200MHz, optimized for clocking in computing and networking 高达 200MHz 的频率, 用于在计算机和网络设备的时钟



General Specifications 规格参考

PARAMETER	性能参数	KD256C	KD326C	KD506C	KD706C	KD326C	KD506C	KD706C
Package size/pad	尺寸/引脚数	2.5x2.0mm/6				-		
		3.2x2.5mm/6				3.2x2.5mm/6		
		5.0x3.2mm/6				5.0x3.2mm/6		
		7.0x5.0mm/6				7.0x5.0mm/6		
Frequency Range	频率范围	13.5MHz ~ 200MHz			100MHz~250MHz			
Supply Voltage	供给电压	+1.8V/2.5V/3.3V(±10%)						
Output Logic	输出波形	HCSL						
Frequency Tolerance	调整频差	±30ppm max.						
Frequency Stability	温度频差	见下表						
Operating Temperature Range	温度范围	见下表						
Current Consumption (15pF load)	工作电流	40mA max.						
Output Load	输出负载	50Ω to ground on each output						
Start-up Time	起振时间	10ms max.						
Duty Cycle	占空比	45~55% (f≤40MHz); 40~60% (f > 40MHz)						
Rise & Fall Time	上升下降时间	0.8ns max.						
Output Enable/Disable Time	启动/禁用时间	Enable: 10ms max. Disable: 0.2μs max.						
Output Logic High "1" Output Logic Low "0"	输出电平 高 输出电平 低	高=400mV min, 750mV typ. 低=-150mV~150mV @1.8V 高=550mV~850mV 低=-150mV~150mV @2.5V 高=550mV~850mV 低=-150mV~150mV @3.3V						
Output Voltage Swing	输出电压波动	400mV min. @1.8V; 500mV min. @2.5V; 600mV min. @3.3V						
RMS Phase Jitter [12KHz~20MHz]	抖动	0.2ps typ.; 0.5ps max.			50fs typ.; 300fs max.			
Storage Temperature Range	储存温度范围	-55°C ~ +125°C						
Aging Per Year	年化率	±3ppm ~ ±5ppm/year						

Frequency Stability 温度频差 VS Operating Temperature Range 温度范围

Temp. Code	Temp. ppm	±20	±25	±30	±50	±100
B	-20~70°C	○	○	○	○	○
C	-40~85°C		○	○	○	○
E	-40~105°C				○	○
F	-55~125°C					○

NOTE: Please consult for other specifications 若有其它规格需求请告知

Outline Dimensions (Unit: mm) 外形尺寸

<p>KD256C</p>																									
<p>KD326C</p>																									
<p>KD506C</p>																									
<p>KD706C</p>																									
	<table border="1" data-bbox="509 1234 857 1507"> <thead> <tr> <th>Pin</th> <th>Connection</th> </tr> </thead> <tbody> <tr> <td>#1</td> <td>Output Enable (OE)</td> </tr> <tr> <td>#2</td> <td>No Connection</td> </tr> <tr> <td>#3</td> <td>Ground</td> </tr> <tr> <td>#4</td> <td>Output</td> </tr> <tr> <td>#5</td> <td>Complementary</td> </tr> <tr> <td>#6</td> <td>Supply Voltage</td> </tr> </tbody> </table> <table border="1" data-bbox="915 1272 1263 1470"> <thead> <tr> <th colspan="2">Enable/Disable Function</th> </tr> </thead> <tbody> <tr> <td>Input (#1)</td> <td>Output (#4, #5)</td> </tr> <tr> <td>Open</td> <td>Enable</td> </tr> <tr> <td>$V_{IH} \geq 70\%V_{dd}$</td> <td>Enable</td> </tr> <tr> <td>$V_{IL} \leq 30\%V_{dd}$</td> <td>Disable</td> </tr> </tbody> </table>	Pin	Connection	#1	Output Enable (OE)	#2	No Connection	#3	Ground	#4	Output	#5	Complementary	#6	Supply Voltage	Enable/Disable Function		Input (#1)	Output (#4, #5)	Open	Enable	$V_{IH} \geq 70\%V_{dd}$	Enable	$V_{IL} \leq 30\%V_{dd}$	Disable
Pin	Connection																								
#1	Output Enable (OE)																								
#2	No Connection																								
#3	Ground																								
#4	Output																								
#5	Complementary																								
#6	Supply Voltage																								
Enable/Disable Function																									
Input (#1)	Output (#4, #5)																								
Open	Enable																								
$V_{IH} \geq 70\%V_{dd}$	Enable																								
$V_{IL} \leq 30\%V_{dd}$	Disable																								

Test Circuit and Output Waveforms 测试电路图及输出波形

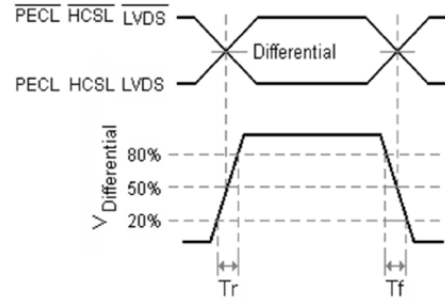
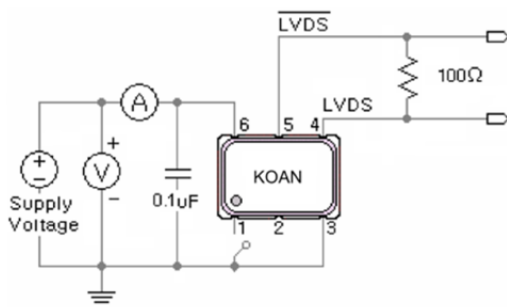

Part Number Guide 产品编号

<u>KD326C</u>	-	<u>20.000</u>	-	<u>33</u>	-	<u>C</u>	-	<u>30</u>	-	<u>NS</u>
↓		↓		↓		↓		↓		↓
型号		标称频率		工作电压		工作温度		温度频差		特殊要求

‘KD’: 差分晶振
 ‘326’:封装尺寸
 SMD 3.2x2.5mm 6 pad
 ‘C’: 输出波形
 HCSL

(In MHz)

18=1.8V
 25=2.5V
 33=3.3V

B: -20~+70°C
 C: -40~+85°C
 E: -40~+105°C
 F: -55~+125°C

10 = ±10ppm
 20 = ±20ppm
 30 = ±30ppm
 50 = ±50ppm
 100 = ±100ppm

‘NS’:特殊要求

Reflow Profile 回流焊

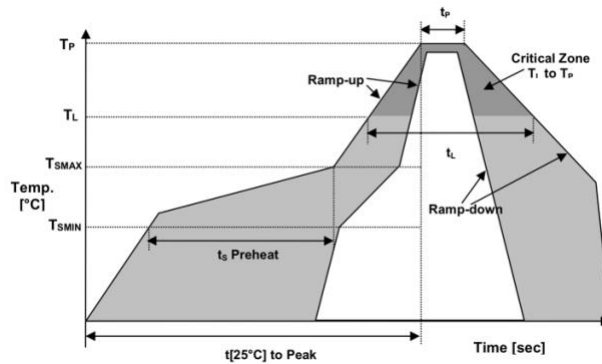

Temperature Min Preheat	最低预热温度	T_{smin}	150°C
Temperature Max preheat	最高预热温度	T_{smax}	200°C
Time (T_{smin} to T_{smax})	时间差	T_s	60~120 sec
Temperature	温度	T_L	217°C
Peak Temperature	最高温	T_p	260 °C
Ramp-up Rate	升温速度	R_{up}	3°C/sec max
Ramp-down Rate	降温速度	R_{down}	6°C/sec max
Time within 5°C of Peak Temperature	最高温度停留时间	t_p	30 sec
Time $t[25°C]$ to peak temperature	25度到最高温度时间	$t[25°C]$ to peak	480 sec
Time	时间	t_L	60~150 sec